



QM30VT3 High-Performance 3-Axis Vibration and Temperature Sensor with IO-Link

Original Instructions

p/n: 252274 Rev. B

10-Feb-26

© Banner Engineering Corp. All rights reserved. www.bannerengineering.com

Contents

Chapter 1 Features	3
Models	3
IO-Link Overview	3
Specifications	4
FCC Part 15 Class B for Unintentional Radiators	4
Industry Canada ICES-003(B)	5
Dimensions	5
Chapter 2 Overview	6
High-Performance Third Axis	6
High-Frequency Enveloping (HFE) or Demodulation	6
Adjustable FMax Settings	6
VIBE-IQ Integration	7
Status Indicators	7
Chapter 3 Configuration Instructions	8
Scalar Data Glossary	8
IO-Link Data Map	8
Communication Parameters	8
Process Data Modes 0 and 2: Primary Floating Point	9
Process Data Modes 1 and 3: Primary Smart Sensor	13
Process Data Mode 4: User Profile Floating Point	18
Process Data Mode 5: User Profile Smart Sensor	23
IO-Link Process Data Out (Master to Device)	27
Parameters Set Using IO-Link	27
Chapter 4 Installation Instructions	44
QM30VT3 IO-Link Wiring	44
Installing the QM30VT3 Sensor	44
Chapter 5 Accessories	46
Brackets	46
Cordsets	47
Chapter 6 Product Support and Maintenance	48
Repairs	48
Contact Us	48
Banner Engineering Corp Limited Warranty	48

Chapter Contents

Models 3
 IO-Link Overview 3
 Specifications 4

Chapter 1 Features

Unlock insights into machine health with the QM30VT3 High-Performance 3-Axis Vibration and Temperature Sensor with IO-Link. Engineered to continuously monitor and predict failures in rotating machinery, this advanced sensor enables proactive maintenance strategies.



- **Precision Monitoring**—Ultra-low noise 3-axis vibration sensing up to 5.3 kHz captures subtle anomalies, from early bearing wear to misalignment.
- **Actionable Intelligence**—Delivers RMS Velocity, RMS High-Frequency Acceleration, and Peak Velocity data, pre-processed for immediate diagnostics and decision-making.
- **IO-Link Process Data**—Available as floating point or smart sensor integer-based values in imperial or metric units
- **Discrete Output**—For use with local fault indication or with a sensor without an IO-Link master (configured using IO-Link)
- **Adaptable and Robust**—Adjustable FMax settings optimize diagnostic capabilities, while its compact 30mm form factor fits snugly into any machine setup.
- **Built to Last**—Industrial-grade stainless steel or aluminum housing ensures durability in the harshest conditions, from factory floors to remote installations.
- **VIBE-IQ® Integration**—Use Banner’s machine learning algorithm for baselining an asset and automatically generating threshold levels and alert feedback
- **Seamless Integration**—Connects effortlessly using the IO-Link interface for configuration and communication for simplified Warning and Alarm threshold setup for alert feedback while enabling real-time data access from all types of assets and locations.

For additional information, updated documentation, and a list of accessories, refer to Banner Engineering's website, www.bannerengineering.com.

Models

Models	Housing Type	Connections and Cable	Inputs and Outputs
QM30VT3-SS-KQP	316L stainless steel	IO-Link communications; 150 mm (6 in) cable with a 5-pin M12 male quick disconnect (QD)	Vibration and temperature
QM30VT3-KQP	Aluminum		

The measured sensor values are available via Process Data In. For more information, see the QM30VT3-KQP IO-Link IODD file p/n 252678).

IO-Link Overview

IO-Link is an open standard serial communication protocol that allows for the bi-directional exchange of data from IO-Link-supported devices, such as sensors, that are connected through IO-Link.

Advantages to an IO-Link system include standardized wiring, remote configuration, simple device replacement, advanced diagnostics, and increased data availability. Because IO-Link is an open standard, the devices can be integrated in almost any fieldbus or automation system.

An IO-Link system consists of an IO-Link master and an IO-Link device such as a sensor, lighting product, IO-Link hub, or actuator.

The functions and parameters of the IO-Link devices are represented in a device description file (IODD). IODD files contain information about identification, device parameters, process and diagnostic data, communication properties, and other details. The IODD files for Banner IO-link devices can be downloaded for free on www.bannerengineering.com.

Specifications

Supply Voltage

18 V DC to 30 V DC at 50 mA maximum

Analog Input Impedance

Approximately 450 ohms

Supply Protection Circuitry

Protected against reverse polarity and transient voltages

Leakage Current Immunity

400 μ A

Indicators

Green LED: Power

Amber LED 1: IO-Link communications active

Red LED 2: Discrete output state active

See "Status Indicators" on page 7

Connections

4-pin M12 male/female quick-disconnect connectors

Construction

Coupling Material: Nickel-plated brass or stainless steel, depending on the model

Connector Body: PVC translucent black

Mounting Options

The sensor can be mounted using a variety of methods, including M4 \times 0.7 hex screw, epoxy, thermal tape, or magnetic mount.

Mechanical Shock

MIL-STD-202G, Method 213B, Condition I (100G 6x along X, Y, and Z axes, 18 shocks), with device operating

Certifications



Banner Engineering BV
Park Lane, Culliganlaan 2F bus 3
1831 Diegem, BELGIUM



Turck Banner LTD Blenheim House
Blenheim Court
Wickford, Essex SS11 8YT
GREAT BRITAIN

Vibration Sensor

Sensor Type: Ultralow noise Digital MEMS

Number of axes: 3

Measuring Range: $\pm 16G$, 0 to 65.5 mm/s or 0 to 6.5 in/s RMS

Frequency Range: 6 Hz to 5.3 kHz

Accuracy: $\pm 5\%$ at 25 $^{\circ}C$

Sampling Frequency: 26.80 kHz (default)

Time Waveform Record Length: 4096 points

FFT Lines of Resolution: 1600

FMax Settings (sample duration): 5300 Hz (default 300 ms), 2650 Hz (610 ms), 1300 Hz (1.215 s), 650 Hz (2.43 s), or 325 Hz (4.865 s)

Temperature Sensor

Measuring Range: $-40^{\circ}C$ to $+105^{\circ}C$ ($-40^{\circ}F$ to $+221^{\circ}F$)

Resolution: $\pm 1^{\circ}C$ ($\pm 1.8^{\circ}F$)

Accuracy: $\pm 3^{\circ}C$ ($\pm 5.4^{\circ}F$)

Operating the sensor at higher voltages and faster sampling rates can induce internal heating that can reduce accuracy.

Environmental Rating

Aluminum housing: IP67

Stainless steel housing: IP69K per DIN 40050-9

Operating Temperature

$-40^{\circ}C$ to $+105^{\circ}C$ ($-40^{\circ}F$ to $+221^{\circ}F$) ⁽¹⁾

Product Identification



⁽¹⁾ Operating the devices at the maximum operating conditions for extended periods can shorten the life of the device.

WARNING:



- Do not use this device for personnel protection
- Using this device for personnel protection could result in serious injury or death.
- This device does not include the self-checking redundant circuitry necessary to allow its use in personnel safety applications. A device failure or malfunction can cause either an energized (on) or de-energized (off) output condition.

FCC Part 15 Class B for Unintentional Radiators

(Part 15.105(b)) This equipment has been tested and found to comply with the limits for a Class B digital device, pursuant to part 15 of the FCC Rules. These limits are designed to provide reasonable protection against harmful interference in a residential installation. This equipment generates, uses, and can radiate radio frequency energy and, if not installed and used in accordance with the instructions, may cause harmful interference to radio communications. However, there is no guarantee that interference will not occur in a particular installation. If this equipment does cause harmful interference to radio or television reception, which can be determined by turning the equipment off and on, the user is encouraged to try to correct the interference by one or more of the following measures:

- Reorient or relocate the receiving antenna.
- Increase the separation between the equipment and receiver.
- Connect the equipment into an outlet on a circuit different from that to which the receiver is connected.
- Consult the dealer or an experienced radio/TV technician for help.

(Part 15.21) Any changes or modifications not expressly approved by the party responsible for compliance could void the user's authority to operate this equipment.

Industry Canada ICES-003(B)

This device complies with CAN ICES-3 (B)/NMB-3(B). Operation is subject to the following two conditions: 1) This device may not cause harmful interference; and 2) This device must accept any interference received, including interference that may cause undesired operation.

Cet appareil est conforme à la norme NMB-3(B). Le fonctionnement est soumis aux deux conditions suivantes : (1) ce dispositif ne peut pas occasionner d'interférences, et (2) il doit tolérer toute interférence, y compris celles susceptibles de provoquer un fonctionnement non souhaité du dispositif.

Dimensions

All measurements are listed in millimeters [inches], unless noted otherwise. The measurements provided are subject to change.

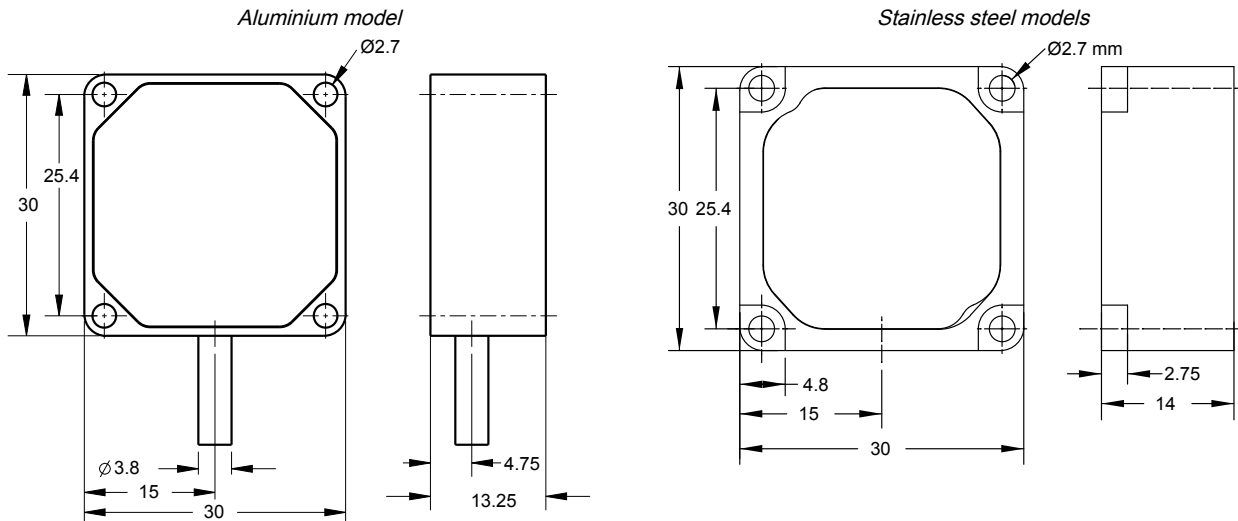

Chapter Contents

High-Performance Third Axis 6
 High-Frequency Enveloping (HFE) or Demodulation 6
 Adjustable FMax Settings 6
 VIBE-IQ Integration 7
 Status Indicators 7

Chapter 2 Overview

High-Performance Third Axis

Banner’s 3-axis vibration and temperature monitoring solutions use a digital MEMS sensor for collecting vibration data. The ultra-low noise density on all three axes ensures accurate data no matter the sensor orientation to prevent maintenance decisions from being made because of the bad trending of false data. Most 3-axis MEMS sensors only offer a low noise profile on two axes with the third axis (typically the Z or Vertical Radial Axis) having two to three times the noise density, causing that third axis to have inaccurate data. This inaccurate data leads to maintenance decisions made without a true fault present.

High-Frequency Enveloping (HFE) or Demodulation

High-frequency enveloping (HFE), or demodulation, is a separate measurement type and signal processing technique that is very sensitive to high-frequency impacts and friction.

HFE can be useful for diagnosing bearing defects, lubrication issues, cavitation, and gear faults. These types of faults produce very low-energy impacts/forces that can make them difficult to detect in their early stages with standard vibration measurements because they can be drowned out by the machine’s fundamental forces. HFE trends the values to detect early faults so maintenance can occur before a downtime event occurs.

When paired with a lower FMax setting, the sample frequency still remains at maximum but the sensor takes a much longer sample. This data is used to trend early defects on slow-speed assets that would normally require a special ultrasound accelerometer.

Adjustable FMax Settings

The vibration/temperature sensor has optional settings to increase the frequency resolution of the measurement through the adjustable FMax settings.

Adjusting the FMax setting allows users to control the trade-off between frequency resolution, bandwidth, and measurement duration.

Lower FMax settings provide finer frequency resolution but reduce the total bandwidth and increase the measurement time, whereas higher FMax settings broaden the frequency range but may sacrifice resolution.

FMax is critical in vibration analysis because it determines the sensor’s capability to detect and characterize different vibration frequencies, which is essential for diagnosing machinery health, identifying faults, and optimizing maintenance strategies.

FMax Settings

Setting	Frequency (Hz)	Resolution (Hz)	Sample Duration
1	5300	3.29	300 ms
2	2650	1.65	610 ms
3	1300	0.82	1.215 s
4	650	0.41	2.43 s
5	325	0.21	4.86 s

VIBE-IQ Integration

The QM30VT3 uses Banner’s VIBE-IQ® machine learning algorithm to make vibration data analysis much easier.

VIBE-IQ automatically generates a baseline of an asset, generates warning and alarm thresholds, and sets alert flags to get immediate feedback of potential issues. This greatly simplifies the process of gaining valuable insight into the health of an asset.

More details about the register map and configuration of VIBE-IQ within the QM30VT3 can be found in the QM30VT3 VIBE-IQ Technical Note found on our website at www.bannerengineering.com.

Status Indicators

Indicator	Flashing	On	Off
Green		Power is on	Power is off
Amber	IO-Link communications are active (flash rate of 900 ms on, 100 ms off)		IO-Link Communications are not present
Red		If the discrete output is selected, the discrete output state is active	If the discrete output is selected, the discrete output state is not active. The discrete output is not selected

Chapter Contents

Scalar Data Glossary 8
 IO-Link Data Map 8

Chapter 3 Configuration Instructions

Scalar Data Glossary

The following list defines many of the available parameters on the Banner QM30VT3 Vibration and Temperature Sensor.

Velocity

Measures a moving or vibrating mass's speed.

Velocity is used in the lower frequency part of the vibration measurement to indicate many types of vibration faults, such as unbalance, misalignment, soft foot, looseness, eccentricity, etc. Trending velocity over time with continuous monitoring can indicate these faults early.

High-Frequency Acceleration

Useful metric for early high-frequency fault detection when trended for bearing faults, cavitation, gear mesh, rotor rubs, lubrication issues, etc.

Crest Factor

Peak Acceleration / RMS Acceleration. This unitless ratio defines how a signal peaks and is used to predict an impact. Increasing crest factor tends to be an early indicator of bearing faults.

Kurtosis

Unitless statistical measure of the tailedness of a normal distribution of the data.

Kurtosis represents the probability or frequency of values that are extremely high or low compared to the mean. Values around three (3) indicate moderate outlier frequency (normal distribution); less than three (3) indicates lower outlier frequency, and above three (3) indicates higher outlier frequency.

Peak Velocity/Acceleration Frequency Component

Provides the frequency where the highest peak of either velocity or acceleration occurred within the specified bandwidth. Can be useful for detecting motor fundamental frequencies or fault frequencies as they appear.

Asset Run Flag

Uses the measured acceleration data to determine if the asset is running or is offline.

Magnitude

$\sqrt{X^2 + Y^2 + Z^2}$; Provides the magnitude of all three vectors and is specifically used for high-frequency acceleration measurement where the direction is less important and the trend of the overall value of the data can be used in a single point.

IO-Link Data Map

This document refers to the following IODD file: Banner_Engineering-QM30VT3-KQP-20251016-IODD1.1.xml.

The IODD file and support files can be found on www.bannerengineering.com under the download section of the product family page.

Communication Parameters

The following communication parameters are used.

Parameter	Value	Parameter	Value
IO-Link revision	V1.1	Port class	A
Process Data In length	256 bits	SIO mode	No
Process Data Out length	N/A	Smart Sensor Profile	Yes
Bit Rate	38400 bps	Block parameterization	Yes

Continued on page 9

Continued from page 8

Parameter	Value	Parameter	Value
Minimum cycle time	4 ms	Data Storage	Yes
Device ID	659481 (0x0a1019)		

Process Data Modes 0 and 2: Primary Floating Point

Mode 0 units: in/sec

Mode 2 units: mm/sec

Subindex	Name	Number of Bits
1	X-Axis RMS Velocity	32
2	Y-Axis RMS Velocity	32
3	Z-Axis RMS Velocity	32
4	X-Axis High Frequency RMS Acceleration	32
5	Y-Axis High Frequency RMS Acceleration	32
6	Z-Axis High Frequency RMS Acceleration	32
7	Mode 0: Temperature F Mode 2: Temperature C	32
8	X Vel Acute Warning	1
9	X Vel Acute Alarm	1
10	X Vel Chronic Warning	1
11	X Vel Chronic Alarm	1
12	X HiFreq Accel Acute Warning	1
13	X HiFreq Accel Acute Alarm	1
14	X HiFreq Accel Chronic Warning	1
15	X HiFreq Accel Chronic Alarm	1
16	Y Vel Acute Warning	1
17	Y Vel Acute Alarm	1
18	Y Vel Chronic Warning	1
19	Y Vel Chronic Alarm	1
20	Y HiFreq Accel Acute Warning	1
21	Y HiFreq Accel Acute Alarm	1
22	Y HiFreq Accel Chronic Warning	1
23	Y HiFreq Accel Chronic Alarm	1
24	Z Vel Acute Warning	1
25	Z Vel Acute Alarm	1
26	Z Vel Chronic Warning	1
27	Z Vel Chronic Alarm	1
28	Z HiFreq Accel Acute Warning	1
29	Z HiFreq Accel Acute Alarm	1
30	Z HiFreq Accel Chronic Warning	1
31	Z HiFreq Accel Chronic Alarm	1
32	Temp Warning	1
33	Temp Alarm	1

Octet 0

Subindex							33	32
Bit Offset	255	254	253	252	251	250	249	248
Value	0	0	0	0	0	0	1	1

Octet 1

Subindex	31	30	29	28	27	26	25	24
Bit Offset	247	246	245	244	243	242	241	240
Value	1	1	1	1	1	1	1	1

Octet 2

Subindex	23	22	21	20	19	18	17	16
Bit Offset	239	238	237	236	235	234	233	232
Value	1	1	1	1	1	1	1	1

Octet 3

Subindex	15	14	13	12	11	10	9	8
Bit Offset	231	230	229	228	227	226	225	224
Value	1	1	1	1	1	1	1	1

Octet 4

Subindex	7	7	7	7	7	7	7	7
Bit Offset	223	222	221	220	219	218	217	216
Value	1	1	1	1	1	1	1	1

Octet 5

Subindex	7	7	7	7	7	7	7	7
Bit Offset	215	214	213	212	211	210	209	208
Value	1	1	1	1	1	1	1	1

Octet 6

Subindex	7	7	7	7	7	7	7	7
Bit Offset	207	206	205	204	203	202	201	200
Value	1	1	1	1	1	1	1	1

Octet 7

Subindex	7	7	7	7	7	7	7	7
Bit Offset	199	198	197	196	195	194	193	192
Value	1	1	1	1	1	1	1	1

Octet 8

Subindex	6	6	6	6	6	6	6	6
Bit Offset	191	190	189	188	187	186	185	184

Continued on page 11

Continued from page 10

Value	1	1	1	1	1	1	1	1
-------	---	---	---	---	---	---	---	---

Octet 9

Subindex	6	6	6	6	6	6	6	6
Bit Offset	183	182	181	180	179	178	177	176
Value	1	1	1	1	1	1	1	1

Octet 10

Subindex	6	6	6	6	6	6	6	6
Bit Offset	175	174	173	172	171	170	169	168
Value	1	1	1	1	1	1	1	1

Octet 11

Subindex	6	6	6	6	6	6	6	6
Bit Offset	167	166	165	164	163	162	161	160
Value	1	1	1	1	1	1	1	1

Octet 12

Subindex	5	5	5	5	5	5	5	5
Bit Offset	159	158	157	156	155	154	153	152
Value	1	1	1	1	1	1	1	1

Octet 13

Subindex	5	5	5	5	5	5	5	5
Bit Offset	151	150	149	148	147	146	145	144
Value	1	1	1	1	1	1	1	1

Octet 14

Subindex	5	5	5	5	5	5	5	5
Bit Offset	143	142	141	140	139	138	137	136
Value	1	1	1	1	1	1	1	1

Octet 15

Subindex	5	5	5	5	5	5	5	5
Bit Offset	135	134	133	132	131	130	129	128
Value	1	1	1	1	1	1	1	1

Octet 16

Subindex	4	4	4	4	4	4	4	4
Bit Offset	127	126	125	124	123	122	121	120
Value	1	1	1	1	1	1	1	1

Octet 17

Octet 17								
Subindex	4	4	4	4	4	4	4	4
Bit Offset	119	118	117	116	115	114	113	112
Value	1	1	1	1	1	1	1	1

Octet 18

Subindex	4	4	4	4	4	4	4	4
Bit Offset	111	110	109	108	107	106	105	104
Value	1	1	1	1	1	1	1	1

Octet 19

Subindex	4	4	4	4	4	4	4	4
Bit Offset	103	102	101	100	99	98	97	96
Value	1	1	1	1	1	1	1	1

Octet 20

Subindex	3	3	3	3	3	3	3	3
Bit Offset	95	94	93	92	91	90	89	88
Value	1	1	1	1	1	1	1	1

Octet 21

Subindex	3	3	3	3	3	3	3	3
Bit Offset	87	86	85	84	83	82	81	80
Value	1	1	1	1	1	1	1	1

Octet 22

Subindex	3	3	3	3	3	3	3	3
Bit Offset	79	78	77	76	75	74	73	72
Value	1	1	1	1	1	1	1	1

Octet 23

Subindex	3	3	3	3	3	3	3	3
Bit Offset	71	70	69	68	67	66	65	64
Value	1	1	1	1	1	1	1	1

Octet 24

Subindex	2	2	2	2	2	2	2	2
Bit Offset	63	62	61	60	59	58	57	56
Value	1	1	1	1	1	1	1	1

Octet 25

Subindex	2	2	2	2	2	2	2	2
----------	---	---	---	---	---	---	---	---

Continued on page 13

Continued from page 12

Bit Offset	55	54	53	52	51	50	49	48
Value	1	1	1	1	1	1	1	1

Octet 26

Subindex	2	2	2	2	2	2	2	2
Bit Offset	47	46	45	44	43	42	41	40
Value	1	1	1	1	1	1	1	1

Octet 27

Subindex	2	2	2	2	2	2	2	2
Bit Offset	39	38	37	36	35	34	33	32
Value	1	1	1	1	1	1	1	1

Octet 28

Subindex	1	1	1	1	1	1	1	1
Bit Offset	31	30	29	28	27	26	25	24
Value	1	1	1	1	1	1	1	1

Octet 29

Subindex	1	1	1	1	1	1	1	1
Bit Offset	23	22	21	20	19	18	17	16
Value	1	1	1	1	1	1	1	1

Octet 30

Subindex	1	1	1	1	1	1	1	1
Bit Offset	15	14	13	12	11	10	9	8
Value	1	1	1	1	1	1	1	1

Octet 31

Subindex	1	1	1	1	1	1	1	1
Bit Offset	7	6	5	4	3	2	1	0
Value	1	1	1	1	1	1	1	1

Process Data Modes 1 and 3: Primary Smart Sensor

Mode 1 units: in/sec

Mode 3 units: mm/sec

Subindex	Name	Number of Bits
1	X-Axis RMS Velocity	16
2	Scale	8
3	X Vel Acute Warning	1
4	X Vel Acute Alarm	1
5	X Vel Chronic Warning	1

Continued on page 14

Continued from page 13

Subindex	Name	Number of Bits
6	X Vel Chronic Alarm	1
7	Y-Axis RMS Velocity	16
8	Scale	8
9	Y Vel Acute Warning	1
10	Y Vel Acute Alarm	1
11	Y Vel Chronic Warning	1
12	Y Vel Chronic Alarm	1
13	Z-Axis RMS Velocity	16
14	Scale	8
15	Z Vel Acute Warning	1
16	Z Vel Acute Alarm	1
17	Z Vel Chronic Warning	1
18	Z Vel Chronic Alarm	1
19	X-Axis High Frequency RMS Acceleration	16
20	Scale	8
21	X HiFreq Accel Acute Warning	1
22	X HiFreq Accel Acute Alarm	1
23	X HiFreq Accel Chronic Warning	1
24	X HiFreq Accel Chronic Alarm	1
25	Y-Axis High Frequency RMS Acceleration	16
26	Scale	8
27	Y HiFreq Accel Acute Warning	1
28	Y HiFreq Accel Acute Alarm	1
29	Y HiFreq Accel Chronic Warning	1
30	Y HiFreq Accel Chronic Alarm	1
31	Z-Axis High Frequency RMS Acceleration	16
32	Scale	8
33	Z HiFreq Accel Acute Warning	1
34	Z HiFreq Accel Acute Alarm	1
35	Z HiFreq Accel Chronic Warning	1
36	Z HiFreq Accel Chronic Alarm	1
37	Mode 1: Temperature F Mode 3: Temperature C	16
38	Scale	8
39	Temp Warning	1
40	Temp Alarm	1

Octet 0

Subindex								
Bit Offset	255	254	253	252	251	250	249	248
Value	0	0	0	0	0	0	0	0

Octet 1

Subindex								
Bit Offset	247	246	245	244	243	242	241	240
Value	0	0	0	0	0	0	0	0

Octet 2

Subindex								
Bit Offset	239	238	237	236	235	234	233	232
Value	0	0	0	0	0	0	0	0

Octet 3

Subindex								
Bit Offset	231	230	229	228	227	226	225	224
Value	0	0	0	0	0	0	0	0

Octet 4

Subindex							40	39
Bit Offset	223	222	221	220	219	218	217	216
Value	0	0	0	0	0	0	1	1

Octet 5

Subindex	38	38	38	38	38	38	38	38
Bit Offset	215	214	213	212	211	210	209	208
Value	1	1	1	1	1	1	1	1

Octet 6

Subindex	37	37	37	37	37	37	37	37
Bit Offset	207	206	205	204	203	202	201	200
Value	1	1	1	1	1	1	1	1

Octet 7

Subindex	37	37	37	37	37	37	37	37
Bit Offset	199	198	197	196	195	194	193	192
Value	1	1	1	1	1	1	1	1

Octet 8

Subindex					36	35	34	33
Bit Offset	191	190	189	188	187	186	185	184
Value	0	0	0	0	1	1	1	1

Octet 9

Subindex	32	32	32	32	32	32	32	32
Bit Offset	183	182	181	180	179	178	177	176

Continued on page 16

Continued from page 15

Value	1	1	1	1	1	1	1	1
-------	---	---	---	---	---	---	---	---

Octet 10

Subindex	31	31	31	31	31	31	31	31
Bit Offset	175	174	173	172	171	170	169	168
Value	1	1	1	1	1	1	1	1

Octet 11

Subindex	31	31	31	31	31	31	31	31
Bit Offset	167	166	165	164	163	162	161	160
Value	1	1	1	1	1	1	1	1

Octet 12

Subindex					30	29	28	27
Bit Offset	159	158	157	156	155	154	153	152
Value	0	0	0	0	1	1	1	1

Octet 13

Subindex	26	26	26	26	26	26	26	26
Bit Offset	151	150	149	148	147	146	145	144
Value	1	1	1	1	1	1	1	1

Octet 14

Subindex	25	25	25	25	25	25	25	25
Bit Offset	143	142	141	140	139	138	137	136
Value	1	1	1	1	1	1	1	1

Octet 15

Subindex	25	25	25	25	25	25	25	25
Bit Offset	135	134	133	132	131	130	129	128
Value	1	1	1	1	1	1	1	1

Octet 16

Subindex					24	23	22	21
Bit Offset	127	126	125	124	123	122	121	120
Value	0	0	0	0	1	1	1	1

Octet 17

Subindex	20	20	20	20	20	20	20	20
Bit Offset	119	118	117	116	115	114	113	112
Value	1	1	1	1	1	1	1	1

Octet 18

Subindex	19	19	19	19	19	19	19	19
Bit Offset	111	110	109	108	107	106	105	104
Value	1	1	1	1	1	1	1	1

Octet 19

Subindex	19	19	19	19	19	19	19	19
Bit Offset	103	102	101	100	99	98	97	96
Value	1	1	1	1	1	1	1	1

Octet 20

Subindex					18	17	16	15
Bit Offset	95	94	93	92	91	90	89	88
Value	0	0	0	0	1	1	1	1

Octet 21

Subindex	14	14	14	14	14	14	14	14
Bit Offset	87	86	85	84	83	82	81	80
Value	1	1	1	1	1	1	1	1

Octet 22

Subindex	13	13	13	13	13	13	13	13
Bit Offset	79	78	77	76	75	74	73	72
Value	1	1	1	1	1	1	1	1

Octet 23

Subindex	13	13	13	13	13	13	13	13
Bit Offset	71	70	69	68	67	66	65	64
Value	1	1	1	1	1	1	1	1

Octet 24

Subindex					12	11	10	9
Bit Offset	63	62	61	60	59	58	57	56
Value	0	0	0	0	1	1	1	1

Octet 25

Subindex	8	8	8	8	8	8	8	8
Bit Offset	55	54	53	52	51	50	49	48
Value	1	1	1	1	1	1	1	1

Octet 26

Subindex	7	7	7	7	7	7	7	7
Bit Offset	47	46	45	44	43	42	41	40

Continued on page 18

Continued from page 17

Value	1	1	1	1	1	1	1	1
-------	---	---	---	---	---	---	---	---

Octet 27

Subindex	7	7	7	7	7	7	7	7
Bit Offset	39	38	37	36	35	34	33	32
Value	1	1	1	1	1	1	1	1

Octet 28

Subindex					6	5	4	3
Bit Offset	31	30	29	28	27	26	25	24
Value	0	0	0	0	1	1	1	1

Octet 29

Subindex	2	2	2	2	2	2	2	2
Bit Offset	23	22	21	20	19	18	17	16
Value	1	1	1	1	1	1	1	1

Octet 30

Subindex	1	1	1	1	1	1	1	1
Bit Offset	15	14	13	12	11	10	9	8
Value	1	1	1	1	1	1	1	1

Octet 31

Subindex	1	1	1	1	1	1	1	1
Bit Offset	7	6	5	4	3	2	1	0
Value	1	1	1	1	1	1	1	1

Process Data Mode 4: User Profile Floating Point

Subindex	Name	Number of Bits
1	Metric 1	32
2	Metric 2	32
3	Metric 3	32
4	Metric 4	32
5	Metric 5	32
6	Metric 6	32
7	Metric 7	32
8	M1 Chan 1 Warning	1
9	M1 Chan 2 Alarm	1
10	M2 Chan 1 Warning	1
11	M2 Chan 2 Alarm	1
12	M3 Chan 1 Warning	1
13	M3 Chan 2 Alarm	1

Continued on page 19

Continued from page 18

Subindex	Name	Number of Bits
14	M4 Chan 1 Warning	1
15	M4 Chan 2 Alarm	1
16	M5 Chan 1 Warning	1
17	M5 Chan 2 Alarm	1
18	M6 Chan 1 Warning	1
19	M6 Chan 2 Alarm	1
20	M7 Chan 1 Warning	1
21	M7 Chan 2 Alarm	1

Octet 0

Subindex								
Bit Offset	255	254	253	252	251	250	249	248
Value	0	0	0	0	0	0	0	0

Octet 1

Subindex								
Bit Offset	247	246	245	244	243	242	241	240
Value	0	0	0	0	0	0	0	0

Octet 2

Subindex								
Bit Offset	239	238	237	236	235	234	233	232
Value	0	0	0	0	0	0	0	0

Octet 3

Subindex								
Bit Offset	231	230	229	228	227	226	225	224
Value	0	0	0	0	0	0	0	0

Octet 4

Subindex							28	27
Bit Offset	223	222	221	220	219	218	217	216
Value	0	0	0	0	0	0	1	1

Octet 5

Subindex	26	26	26	26	26	26	26	26
Bit Offset	215	214	213	212	211	210	209	208
Value	1	1	1	1	1	1	1	1

Octet 6

Subindex	25	25	25	25	25	25	25	25
Bit Offset	207	206	205	204	203	202	201	200

Continued on page 20

Continued from page 19

Value	1	1	1	1	1	1	1	1
-------	---	---	---	---	---	---	---	---

Octet 7

Subindex	25	25	25	25	25	25	25	25
Bit Offset	199	198	197	196	195	194	193	192
Value	1	1	1	1	1	1	1	1

Octet 8

Subindex							24	23
Bit Offset	191	190	189	188	187	186	185	184
Value	0	0	0	0	1	1	1	1

Octet 9

Subindex	22	22	22	22	22	22	22	22
Bit Offset	183	182	181	180	179	178	177	176
Value	1	1	1	1	1	1	1	1

Octet 10

Subindex	21	21	21	21	21	21	21	21
Bit Offset	175	174	173	172	171	170	169	168
Value	1	1	1	1	1	1	1	1

Octet 11

Subindex	21	21	21	21	21	21	21	21
Bit Offset	167	166	165	164	163	162	161	160
Value	1	1	1	1	1	1	1	1

Octet 12

Subindex							20	19
Bit Offset	159	158	157	156	155	154	153	152
Value	0	0	0	0	1	1	1	1

Octet 13

Subindex	18	18	18	18	18	18	18	18
Bit Offset	151	150	149	148	147	146	145	144
Value	1	1	1	1	1	1	1	1

Octet 14

Subindex	17	17	17	17	17	17	17	17
Bit Offset	143	142	141	140	139	138	137	136
Value	1	1	1	1	1	1	1	1

Octet 15

Subindex	17	17	17	17	17	17	17	17
Bit Offset	135	134	133	132	131	130	129	128
Value	1	1	1	1	1	1	1	1

Octet 16

Subindex							16	15
Bit Offset	127	126	125	124	123	122	121	120
Value	0	0	0	0	1	1	1	1

Octet 17

Subindex	14	14	14	14	14	14	14	14
Bit Offset	119	118	117	116	115	114	113	112
Value	1	1	1	1	1	1	1	1

Octet 18

Subindex	13	13	13	13	13	13	13	13
Bit Offset	111	110	109	108	107	106	105	104
Value	1	1	1	1	1	1	1	1

Octet 19

Subindex	13	13	13	13	13	13	13	13
Bit Offset	103	102	101	100	99	98	97	96
Value	1	1	1	1	1	1	1	1

Octet 20

Subindex							12	11
Bit Offset	95	94	93	92	91	90	89	88
Value	0	0	0	0	1	1	1	1

Octet 21

Subindex	10	10	10	10	10	10	10	10
Bit Offset	87	86	85	84	83	82	81	80
Value	1	1	1	1	1	1	1	1

Octet 22

Subindex	9	9	9	9	9	9	9	9
Bit Offset	79	78	77	76	75	74	73	72
Value	1	1	1	1	1	1	1	1

Octet 23

Subindex	9	9	9	9	9	9	9	9
Bit Offset	71	70	69	68	67	66	65	64

Continued on page 22

Continued from page 21

Value	1	1	1	1	1	1	1	1
-------	---	---	---	---	---	---	---	---

Octet 24

Subindex							8	7
Bit Offset	63	62	61	60	59	58	57	56
Value	0	0	0	0	1	1	1	1

Octet 25

Subindex	6	6	6	6	6	6	6	6
Bit Offset	55	54	53	52	51	50	49	48
Value	1	1	1	1	1	1	1	1

Octet 26

Subindex	5	5	5	5	5	5	5	5
Bit Offset	47	46	45	44	43	42	41	40
Value	1	1	1	1	1	1	1	1

Octet 27

Subindex	5	5	5	5	5	5	5	5
Bit Offset	39	38	37	36	35	34	33	32
Value	1	1	1	1	1	1	1	1

Octet 28

Subindex							4	3
Bit Offset	31	30	29	28	27	26	25	24
Value	0	0	0	0	1	1	1	1

Octet 29

Subindex	2	2	2	2	2	2	2	2
Bit Offset	23	22	21	20	19	18	17	16
Value	1	1	1	1	1	1	1	1

Octet 30

Subindex	1	1	1	1	1	1	1	1
Bit Offset	15	14	13	12	11	10	9	8
Value	1	1	1	1	1	1	1	1

Octet 31

Subindex	1	1	1	1	1	1	1	1
Bit Offset	7	6	5	4	3	2	1	0
Value	1	1	1	1	1	1	1	1

Process Data Mode 5: User Profile Smart Sensor

Subindex	Name	Number of Bits
1	Metric 1	16
2	Scale	8
3	Chan 1 Warning	1
4	Chan 2 Alarm	1
5	Metric 2	16
6	Scale	8
7	Chan 1 Warning	1
8	Chan 2 Alarm	1
9	Metric 3	16
10	Scale	8
11	Chan 1 Warning	1
12	Chan 2 Alarm	1
13	Metric 4	16
14	Scale	8
15	Chan 1 Warning	1
16	Chan 2 Alarm	1
17	Metric 5	16
18	Scale	8
19	Chan 1 Warning	1
20	Chan 2 Alarm	1
21	Metric 6	16
22	Scale	8
23	Chan 1 Warning	1
24	Chan 2 Alarm	1
25	Metric 7	16
26	Scale	8
27	Chan 1 Warning	1
28	Chan 2 Alarm	1

Octet 0

Subindex								
Bit Offset	255	254	253	252	251	250	249	248
Value	0	0	0	0	0	0	0	0

Octet 1

Subindex								
Bit Offset	247	246	245	244	243	242	241	240
Value	0	0	0	0	0	0	0	0

Octet 2

Subindex								
----------	--	--	--	--	--	--	--	--

Continued on page 24

Continued from page 23

Bit Offset	239	238	237	236	235	234	233	232
Value	0	0	0	0	0	0	0	0

Octet 3

Subindex								
Bit Offset	231	230	229	228	227	226	225	224
Value	0	0	0	0	0	0	0	0

Octet 4

Subindex							28	27
Bit Offset	223	222	221	220	219	218	217	216
Value	0	0	0	0	0	0	1	1

Octet 5

Subindex	26	26	26	26	26	26	26	26
Bit Offset	215	214	213	212	211	210	209	208
Value	1	1	1	1	1	1	1	1

Octet 6

Subindex	25	25	25	25	25	25	25	25
Bit Offset	207	206	205	204	203	202	201	200
Value	1	1	1	1	1	1	1	1

Octet 7

Subindex	25	25	25	25	25	25	25	25
Bit Offset	199	198	197	196	195	194	193	192
Value	1	1	1	1	1	1	1	1

Octet 8

Subindex							24	23
Bit Offset	191	190	189	188	187	186	185	184
Value	0	0	0	0	1	1	1	1

Octet 9

Subindex	22	22	22	22	22	22	22	22
Bit Offset	183	182	181	180	179	178	177	176
Value	1	1	1	1	1	1	1	1

Octet 10

Subindex	21	21	21	21	21	21	21	21
Bit Offset	175	174	173	172	171	170	169	168
Value	1	1	1	1	1	1	1	1

Octet 11

Subindex	21	21	21	21	21	21	21	21
Bit Offset	167	166	165	164	163	162	161	160
Value	1	1	1	1	1	1	1	1

Octet 12

Subindex							20	19
Bit Offset	159	158	157	156	155	154	153	152
Value	0	0	0	0	1	1	1	1

Octet 13

Subindex	18	18	18	18	18	18	18	18
Bit Offset	151	150	149	148	147	146	145	144
Value	1	1	1	1	1	1	1	1

Octet 14

Subindex	17	17	17	17	17	17	17	17
Bit Offset	143	142	141	140	139	138	137	136
Value	1	1	1	1	1	1	1	1

Octet 15

Subindex	17	17	17	17	17	17	17	17
Bit Offset	135	134	133	132	131	130	129	128
Value	1	1	1	1	1	1	1	1

Octet 16

Subindex							16	15
Bit Offset	127	126	125	124	123	122	121	120
Value	0	0	0	0	1	1	1	1

Octet 17

Subindex	14	14	14	14	14	14	14	14
Bit Offset	119	118	117	116	115	114	113	112
Value	1	1	1	1	1	1	1	1

Octet 18

Subindex	13	13	13	13	13	13	13	13
Bit Offset	111	110	109	108	107	106	105	104
Value	1	1	1	1	1	1	1	1

Octet 19

Subindex	13	13	13	13	13	13	13	13
Bit Offset	103	102	101	100	99	98	97	96

Continued on page 26

Continued from page 25

Value	1	1	1	1	1	1	1	1
-------	---	---	---	---	---	---	---	---

Octet 20

Subindex							12	11
Bit Offset	95	94	93	92	91	90	89	88
Value	0	0	0	0	1	1	1	1

Octet 21

Subindex	10	10	10	10	10	10	10	10
Bit Offset	87	86	85	84	83	82	81	80
Value	1	1	1	1	1	1	1	1

Octet 22

Subindex	9	9	9	9	9	9	9	9
Bit Offset	79	78	77	76	75	74	73	72
Value	1	1	1	1	1	1	1	1

Octet 23

Subindex	9	9	9	9	9	9	9	9
Bit Offset	71	70	69	68	67	66	65	64
Value	1	1	1	1	1	1	1	1

Octet 24

Subindex							8	7
Bit Offset	63	62	61	60	59	58	57	56
Value	0	0	0	0	1	1	1	1

Octet 25

Subindex	6	6	6	6	6	6	6	6
Bit Offset	55	54	53	52	51	50	49	48
Value	1	1	1	1	1	1	1	1

Octet 26

Subindex	5	5	5	5	5	5	5	5
Bit Offset	47	46	45	44	43	42	41	40
Value	1	1	1	1	1	1	1	1

Octet 27

Subindex	5	5	5	5	5	5	5	5
Bit Offset	39	38	37	36	35	34	33	32
Value	1	1	1	1	1	1	1	1

Octet 28

Subindex							4	3
Bit Offset	31	30	29	28	27	26	25	24
Value	0	0	0	0	1	1	1	1

Octet 29

Subindex	2	2	2	2	2	2	2	2
Bit Offset	23	22	21	20	19	18	17	16
Value	1	1	1	1	1	1	1	1

Octet 30

Subindex	1	1	1	1	1	1	1	1
Bit Offset	15	14	13	12	11	10	9	8
Value	1	1	1	1	1	1	1	1

Octet 31

Subindex	1	1	1	1	1	1	1	1
Bit Offset	7	6	5	4	3	2	1	0
Value	1	1	1	1	1	1	1	1

IO-Link Process Data Out (Master to Device)

Not applicable.

Parameters Set Using IO-Link

These parameters can be read from and/or written to an QM30VT3 sensor. Also included is information about whether the variable in question is saved during Data Storage and whether the variable came from the IO-Link Smart Sensor Profile.

Unlike Process Data In, which is transmitted from the IO-Link device to the IO-Link master cyclically, these parameters are read or written acyclically as needed.

Index	Subindex	Name	Length	Value Range	Default	Access Rights
0	1-16	Direct Parameter Page 1 (incl. Vendor ID and Device ID)	128		Bit 5:17	RW
2		System Command		129 = Application Reset 131 = Back to Box		WO
16		Vendor Name string		Banner Engineering Corporation		RO
17		Vendor Text string		More Sensors. More Solutions.		RO
18		Product Name string		QM30VT3-KQP		RO
19		Product ID string		QM30VT3-KQP		RO
20		Product Text string		QM30VT3-KQP		RO
21		Serial Number				RO
22		Hardware Version				RO
23		Firmware Version				RO
24		App Specific Tag (user-defined)		More Sensors. More Solutions		RW
32		Error Count	16			RO
36		Device Status	8	0 = Device is OK 1 = Maintenance required 2 = Out of specification 3 = Functional check 4 = Failure 5..255 Reserved		RO
37		Detailed Device Status				RO

Continued on page 28

Continued from page 27

Index	Subindex	Name	Length	Value Range	Default	Access Rights
69		All Time Run Time				RO
70		Resettable Run Time				
70	1	Run counter (0.25hr)	32	0..2147483647	0	RW
80	1	Defines the formatting of the Process Data	8	0 = FP Imperial Units, 1 = SSP Imperial Units, 2 = FP Metric Units, 3 = SSP Metric Units, 4 = FP User Define, 5 = SSP User Define	0	RW
81		Wire Mode				
81	1	Output Configuration	8	0 = BannerBus, 1 = Discrete Output	0	RW

Continued on page 29

Continued from page 28

Index	Subindex	Name	Length	Value Range	Default	Access Rights
86	1	Vibration Characteristics Selection 1	16	0 = Disable 1 = X-Axis RMS Velocity (in/sec) (6-1000Hz), 2 = X-Axis High-Frequency RMS Acceleration (G)(1000-5300Hz), 3 = Y-Axis RMS Velocity (in/sec) (6-1000Hz), 4 = Y-Axis High-Frequency RMS Acceleration (G)(1000-5300Hz), 5 = Z-Axis RMS Velocity (in/sec) (6-1000Hz), 6 = Z-Axis High-Frequency RMS Acceleration (G)(1000-5300Hz), 7 = Temperature (°F), 8 = X-Axis Full Band Pk to Pk Acceleration (G)(6-5300Hz), 9 = Y-Axis Full Band Pk to Pk Acceleration (G)(6-5300Hz), 10 = Z-Axis Full Band Pk to Pk Acceleration (G)(6-5300Hz), 11 = X-Axis High-Frequency Pk Acceleration (G)(1000-5300Hz), 12 = Y-Axis High-Frequency Pk Acceleration (G)(1000-5300Hz), 13 = Z-Axis High-Frequency Pk Acceleration (G)(1000-5300Hz), 14 = X-Axis High-Frequency Crest Factor(1000-5300Hz), 15 = Y-Axis High-Frequency Crest Factor(1000-5300Hz), 16 = Z-Axis High-Frequency Crest Factor(1000-5300Hz), 17 = X-Axis High-Frequency Kurtosis(1000-5300Hz), 18 = Y-Axis High-Frequency Kurtosis(1000-5300Hz), 19 = Z-Axis High-Frequency Kurtosis(1000-5300Hz), 20 = X-Axis Full Band Crest Factor (6-5300Hz), 21 = Y-Axis Full Band Crest Factor (6-5300Hz), 22 = Z-Axis Full Band Crest Factor (6-5300Hz), 23 = X-Axis Full Band Kurtosis (6-5300Hz), 24 = Y-Axis Full Band Kurtosis (6-5300Hz), 25 = Z-Axis Full Band Kurtosis (6-5300Hz), 26 = X-Axis Peak Velocity Component Frequency (Hz) (6-1000Hz), 27 = Y-Axis Peak Velocity Component Frequency (Hz) (6-1000Hz), 28 = Z-Axis Peak Velocity Component Frequency (Hz) (6-1000Hz), 29 = Motor Run Flag,	1	RW

Continued on page 30

Continued from page 29

Index	Subindex	Name	Length	Value Range	Default	Access Rights
				30 = X-Axis Full Band Peak Acceleration Frequency (Hz) (6-5300Hz), 31 = Y-Axis Full Band Peak Acceleration Frequency (Hz) (6-5300Hz), 32 = Z-Axis Full Band Peak Acceleration Frequency (Hz) (6-5300Hz), 33 = Magnitude (XYZ) High-Frequency RMS Acceleration* (G) (1000-53), 34 = X-Axis Full Band RMS Acceleration (G)(6-5300Hz), 35 = Y-Axis Full Band RMS Acceleration (G)(6-5300Hz), 36 = Z-Axis Full Band RMS Acceleration (G)(6-5300Hz), 37 = X-Axis RMS Velocity (mm/sec) (6-1000Hz), 39 = Y-Axis RMS Velocity (mm/sec) (6-1000Hz), 41 = Z-Axis RMS Velocity (mm/sec) (6-1000Hz), 43 = Temperature (°C)		
	2	Metric 01 - Warning Threshold	32		0	RW
	3	Metric 01 - Alarm Threshold	32		0	RW

Continued on page 31

Continued from page 30

Index	Subindex	Name	Length	Value Range	Default	Access Rights
				0 = Disable, 1 = X-Axis RMS Velocity (in/sec) (6-1000Hz), 2 = X-Axis High-Frequency RMS Acceleration (G)(1000-5300Hz), 3 = Y-Axis RMS Velocity (in/sec) (6-1000Hz), 4 = Y-Axis High-Frequency RMS Acceleration (G)(1000-5300Hz), 5 = Z-Axis RMS Velocity (in/sec) (6-1000Hz), 6 = Z-Axis High-Frequency RMS Acceleration (G)(1000-5300Hz), 7 = Temperature (°F), 8 = X-Axis Full Band Pk to Pk Acceleration (G)(6-5300Hz), 9 = Y-Axis Full Band Pk to Pk Acceleration (G)(6-5300Hz), 10 = Z-Axis Full Band Pk to Pk Acceleration (G)(6-5300Hz), 11 = X-Axis High-Frequency Pk Acceleration (G)(1000-5300Hz), 12 = Y-Axis High-Frequency Pk Acceleration (G)(1000-5300Hz), 13 = Z-Axis High-Frequency Pk Acceleration (G)(1000-5300Hz), 14 = X-Axis High-Frequency Crest Factor(1000-5300Hz), 15 = Y-Axis High-Frequency Crest Factor(1000-5300Hz), 16 = Z-Axis High-Frequency Crest Factor(1000-5300Hz), 17 = X-Axis High-Frequency Kurtosis(1000-5300Hz), 18 = Y-Axis High-Frequency Kurtosis(1000-5300Hz), 19 = Z-Axis High-Frequency Kurtosis(1000-5300Hz), 20 = X-Axis Full Band Crest Factor (6-5300Hz), 21 = Y-Axis Full Band Crest Factor (6-5300Hz), 22 = Z-Axis Full Band Crest Factor (6-5300Hz), 23 = X-Axis Full Band Kurtosis (6-5300Hz), 24 = Y-Axis Full Band Kurtosis (6-5300Hz), 25 = Z-Axis Full Band Kurtosis (6-5300Hz), 26 = X-Axis Peak Velocity Component Frequency (Hz) (6-1000Hz), 27 = Y-Axis Peak Velocity Component Frequency (Hz) (6-1000Hz), 28 = Z-Axis Peak Velocity Component Frequency (Hz) (6-1000Hz), 29 = Motor Run Flag,		
	4	Vibration Characteristics Selection 2	16		3	RW

Continued on page 32

Continued from page 31

Index	Subindex	Name	Length	Value Range	Default	Access Rights
				30 = X-Axis Full Band Peak Acceleration Frequency (Hz) (6-5300Hz), 31 = Y-Axis Full Band Peak Acceleration Frequency (Hz) (6-5300Hz), 32 = Z-Axis Full Band Peak Acceleration Frequency (Hz) (6-5300Hz), 33 = Magnitude (XYZ) High-Frequency RMS Acceleration* (G) (1000-53), 34 = X-Axis Full Band RMS Acceleration (G)(6-5300Hz), 35 = Y-Axis Full Band RMS Acceleration (G)(6-5300Hz), 36 = Z-Axis Full Band RMS Acceleration (G)(6-5300Hz), 37 = X-Axis RMS Velocity (mm/sec) (6-1000Hz), 39 = Y-Axis RMS Velocity (mm/sec) (6-1000Hz), 41 = Z-Axis RMS Velocity (mm/sec) (6-1000Hz), 43 = Temperature (°C)		
	5	Metric 02 - Warning Threshold	32		0	RW
	6	Metric 02 - Alarm Threshold	32		0	RW

Continued on page 33

Continued from page 32

Index	Subindex	Name	Length	Value Range	Default	Access Rights
				0 = Disable, 1 = X-Axis RMS Velocity (in/sec) (6-1000Hz),0 2 = X-Axis High-Frequency RMS Acceleration (G)(1000-5300Hz), 3 = Y-Axis RMS Velocity (in/sec) (6-1000Hz), 4 = Y-Axis High-Frequency RMS Acceleration (G)(1000-5300Hz), 5 = Z-Axis RMS Velocity (in/sec) (6-1000Hz), 6 = Z-Axis High-Frequency RMS Acceleration (G)(1000-5300Hz), 7 = Temperature (°F), 8 = X-Axis Full Band Pk to Pk Acceleration (G)(6-5300Hz), 9 = Y-Axis Full Band Pk to Pk Acceleration (G)(6-5300Hz), 10 = Z-Axis Full Band Pk to Pk Acceleration (G)(6-5300Hz), 11 = X-Axis High-Frequency Pk Acceleration (G)(1000-5300Hz), 12 = Y-Axis High-Frequency Pk Acceleration (G)(1000-5300Hz), 13 = Z-Axis High-Frequency Pk Acceleration (G)(1000-5300Hz), 14 = X-Axis High-Frequency Crest Factor(1000-5300Hz), 15 = Y-Axis High-Frequency Crest Factor(1000-5300Hz), 16 = Z-Axis High-Frequency Crest Factor(1000-5300Hz), 17 = X-Axis High-Frequency Kurtosis(1000-5300Hz), 18 = Y-Axis High-Frequency Kurtosis(1000-5300Hz), 19 = Z-Axis High-Frequency Kurtosis(1000-5300Hz), 20 = X-Axis Full Band Crest Factor (6-5300Hz), 21 = Y-Axis Full Band Crest Factor (6-5300Hz), 22 = Z-Axis Full Band Crest Factor (6-5300Hz), 23 = X-Axis Full Band Kurtosis (6-5300Hz), 24 = Y-Axis Full Band Kurtosis (6-5300Hz), 25 = Z-Axis Full Band Kurtosis (6-5300Hz), 26 = X-Axis Peak Velocity Component Frequency (Hz) (6-1000Hz), 27 = Y-Axis Peak Velocity Component Frequency (Hz) (6-1000Hz), 28 = Z-Axis Peak Velocity Component Frequency (Hz) (6-1000Hz), 29 = Motor Run Flag,		
	7	Vibration Characteristics Selection 3	16		5	RW

Continued on page 34

Continued from page 33

Index	Subindex	Name	Length	Value Range	Default	Access Rights
				30 = X-Axis Full Band Peak Acceleration Frequency (Hz) (6-5300Hz), 31 = Y-Axis Full Band Peak Acceleration Frequency (Hz) (6-5300Hz), 32 = Z-Axis Full Band Peak Acceleration Frequency (Hz) (6-5300Hz), 33 = Magnitude (XYZ) High-Frequency RMS Acceleration* (G) (1000-53), 34 = X-Axis Full Band RMS Acceleration (G)(6-5300Hz), 35 = Y-Axis Full Band RMS Acceleration (G)(6-5300Hz), 36 = Z-Axis Full Band RMS Acceleration (G)(6-5300Hz), 37 = X-Axis RMS Velocity (mm/sec) (6-1000Hz), 39 = Y-Axis RMS Velocity (mm/sec) (6-1000Hz), 41 = Z-Axis RMS Velocity (mm/sec) (6-1000Hz), 43 = Temperature (°C)		
	8	Metric 03 - Warning Threshold	32		0	RW
	9	Metric 03 - Alarm Threshold	32		0	RW

Continued on page 35

Continued from page 34

Index	Subindex	Name	Length	Value Range	Default	Access Rights
				0 = Disable, 1 = X-Axis RMS Velocity (in/sec) (6-1000Hz), 2 = X-Axis High-Frequency RMS Acceleration (G)(1000-5300Hz), 3 = Y-Axis RMS Velocity (in/sec) (6-1000Hz), 4 = Y-Axis High-Frequency RMS Acceleration (G)(1000-5300Hz), 5 = Z-Axis RMS Velocity (in/sec) (6-1000Hz), 6 = Z-Axis High-Frequency RMS Acceleration (G)(1000-5300Hz), 7 = Temperature (°F), 8 = X-Axis Full Band Pk to Pk Acceleration (G)(6-5300Hz), 9 = Y-Axis Full Band Pk to Pk Acceleration (G)(6-5300Hz), 10 = Z-Axis Full Band Pk to Pk Acceleration (G)(6-5300Hz), 11 = X-Axis High-Frequency Pk Acceleration (G)(1000-5300Hz), 12 = Y-Axis High-Frequency Pk Acceleration (G)(1000-5300Hz), 13 = Z-Axis High-Frequency Pk Acceleration (G)(1000-5300Hz), 14 = X-Axis High-Frequency Crest Factor(1000-5300Hz), 15 = Y-Axis High-Frequency Crest Factor(1000-5300Hz), 16 = Z-Axis High-Frequency Crest Factor(1000-5300Hz), 17 = X-Axis High-Frequency Kurtosis(1000-5300Hz), 18 = Y-Axis High-Frequency Kurtosis(1000-5300Hz), 19 = Z-Axis High-Frequency Kurtosis(1000-5300Hz), 20 = X-Axis Full Band Crest Factor (6-5300Hz), 21 = Y-Axis Full Band Crest Factor (6-5300Hz), 22 = Z-Axis Full Band Crest Factor (6-5300Hz), 23 = X-Axis Full Band Kurtosis (6-5300Hz), 24 = Y-Axis Full Band Kurtosis (6-5300Hz), 25 = Z-Axis Full Band Kurtosis (6-5300Hz), 26 = X-Axis Peak Velocity Component Frequency (Hz) (6-1000Hz), 27 = Y-Axis Peak Velocity Component Frequency (Hz) (6-1000Hz), 28 = Z-Axis Peak Velocity Component Frequency (Hz) (6-1000Hz), 29 = Motor Run Flag,		
	10	Vibration Characteristics Selection 4	16		2	RW

Continued on page 36

Continued from page 35

Index	Subindex	Name	Length	Value Range	Default	Access Rights
				30 = X-Axis Full Band Peak Acceleration Frequency (Hz) (6-5300Hz), 31 = Y-Axis Full Band Peak Acceleration Frequency (Hz) (6-5300Hz), 32 = Z-Axis Full Band Peak Acceleration Frequency (Hz) (6-5300Hz), 33 = Magnitude (XYZ) High-Frequency RMS Acceleration* (G) (1000-53), 34 = X-Axis Full Band RMS Acceleration (G)(6-5300Hz), 35 = Y-Axis Full Band RMS Acceleration (G)(6-5300Hz), 36 = Z-Axis Full Band RMS Acceleration (G)(6-5300Hz), 37 = X-Axis RMS Velocity (mm/sec) (6-1000Hz), 39 = Y-Axis RMS Velocity (mm/sec) (6-1000Hz), 41 = Z-Axis RMS Velocity (mm/sec) (6-1000Hz), 43 = Temperature (°C)		
	11	Metric 04 - Warning Threshold	32		0	RW
	12	Metric 04 - Alarm Threshold	32		0	RW

Continued on page 37

Continued from page 36

Index	Subindex	Name	Length	Value Range	Default	Access Rights
				0 = Disable, 1 = X-Axis RMS Velocity (in/sec) (6-1000Hz), 2 = X-Axis High-Frequency RMS Acceleration (G)(1000-5300Hz), 3 = Y-Axis RMS Velocity (in/sec) (6-1000Hz), 4 = Y-Axis High-Frequency RMS Acceleration (G)(1000-5300Hz), 5 = Z-Axis RMS Velocity (in/sec) (6-1000Hz), 6 = Z-Axis High-Frequency RMS Acceleration (G)(1000-5300Hz), 7 = Temperature (°F), 8 = X-Axis Full Band Pk to Pk Acceleration (G)(6-5300Hz), 9 = Y-Axis Full Band Pk to Pk Acceleration (G)(6-5300Hz), 10 = Z-Axis Full Band Pk to Pk Acceleration (G)(6-5300Hz), 11 = X-Axis High-Frequency Pk Acceleration (G)(1000-5300Hz), 12 = Y-Axis High-Frequency Pk Acceleration (G)(1000-5300Hz), 13 = Z-Axis High-Frequency Pk Acceleration (G)(1000-5300Hz), 14 = X-Axis High-Frequency Crest Factor(1000-5300Hz), 15 = Y-Axis High-Frequency Crest Factor(1000-5300Hz), 16 = Z-Axis High-Frequency Crest Factor(1000-5300Hz), 1 17 = X-Axis High-Frequency Kurtosis(1000-5300Hz), 18 = Y-Axis High-Frequency Kurtosis(1000-5300Hz), 19 = Z-Axis High-Frequency Kurtosis(1000-5300Hz), 20 = X-Axis Full Band Crest Factor (6-5300Hz), 21 = Y-Axis Full Band Crest Factor (6-5300Hz), 22 = Z-Axis Full Band Crest Factor (6-5300Hz), 23 = X-Axis Full Band Kurtosis (6-5300Hz), 24 = Y-Axis Full Band Kurtosis (6-5300Hz), 25 = Z-Axis Full Band Kurtosis (6-5300Hz), 26 = X-Axis Peak Velocity Component Frequency (Hz) (6-1000Hz), 27 = Y-Axis Peak Velocity Component Frequency (Hz) (6-1000Hz), 28 = Z-Axis Peak Velocity Component Frequency (Hz) (6-1000Hz), 29 = Motor Run Flag,		
	13	Vibration Characteristics Selection 5	16		4	RW

Continued on page 38

Continued from page 37

Index	Subindex	Name	Length	Value Range	Default	Access Rights
				30 = X-Axis Full Band Peak Acceleration Frequency (Hz) (6-5300Hz), 31 = Y-Axis Full Band Peak Acceleration Frequency (Hz) (6-5300Hz), 32 = Z-Axis Full Band Peak Acceleration Frequency (Hz) (6-5300Hz), 33 = Magnitude (XYZ) High-Frequency RMS Acceleration* (G) (1000-53), 34 = X-Axis Full Band RMS Acceleration (G)(6-5300Hz), 35 = Y-Axis Full Band RMS Acceleration (G)(6-5300Hz), 36 = Z-Axis Full Band RMS Acceleration (G)(6-5300Hz), 37 = X-Axis RMS Velocity (mm/sec) (6-1000Hz), 39 = Y-Axis RMS Velocity (mm/sec) (6-1000Hz), 41 = Z-Axis RMS Velocity (mm/sec) (6-1000Hz), 43 = Temperature (°C)		
	14	Metric 05 - Warning Threshold	32		0	RW
	15	Metric 05 - Alarm Threshold	32		0	RW

Continued on page 39

Continued from page 38

Index	Subindex	Name	Length	Value Range	Default	Access Rights
				0 = Disable, 1 = X-Axis RMS Velocity (in/sec) (6-1000Hz), 2 = X-Axis High-Frequency RMS Acceleration (G)(1000-5300Hz), 3 = Y-Axis RMS Velocity (in/sec) (6-1000Hz), 4 = Y-Axis High-Frequency RMS Acceleration (G)(1000-5300Hz), 5 = Z-Axis RMS Velocity (in/sec) (6-1000Hz), 6 = Z-Axis High-Frequency RMS Acceleration (G)(1000-5300Hz), 7 = Temperature (°F), 8 = X-Axis Full Band Pk to Pk Acceleration (G)(6-5300Hz), 9 = Y-Axis Full Band Pk to Pk Acceleration (G)(6-5300Hz), 10 = Z-Axis Full Band Pk to Pk Acceleration (G)(6-5300Hz), 11 = X-Axis High-Frequency Pk Acceleration (G)(1000-5300Hz), 12 = Y-Axis High-Frequency Pk Acceleration (G)(1000-5300Hz), 13 = Z-Axis High-Frequency Pk Acceleration (G)(1000-5300Hz), 14 = X-Axis High-Frequency Crest Factor(1000-5300Hz), 15 = Y-Axis High-Frequency Crest Factor(1000-5300Hz), 16 = Z-Axis High-Frequency Crest Factor(1000-5300Hz), 17 = X-Axis High-Frequency Kurtosis(1000-5300Hz), 18 = Y-Axis High-Frequency Kurtosis(1000-5300Hz), 19 = Z-Axis High-Frequency Kurtosis(1000-5300Hz), 20 = X-Axis Full Band Crest Factor (6-5300Hz), 21 = Y-Axis Full Band Crest Factor (6-5300Hz), 22 = Z-Axis Full Band Crest Factor (6-5300Hz), 23 = X-Axis Full Band Kurtosis (6-5300Hz), 24 = Y-Axis Full Band Kurtosis (6-5300Hz), 25 = Z-Axis Full Band Kurtosis (6-5300Hz), 26 = X-Axis Peak Velocity Component Frequency (Hz) (6-1000Hz), 27 = Y-Axis Peak Velocity Component Frequency (Hz) (6-1000Hz), 28 = Z-Axis Peak Velocity Component Frequency (Hz) (6-1000Hz), 29 = Motor Run Flag,		
	16	Vibration Characteristics Selection 6	16		6	RW

Continued on page 40

Continued from page 39

Index	Subindex	Name	Length	Value Range	Default	Access Rights
				30 = X-Axis Full Band Peak Acceleration Frequency (Hz) (6-5300Hz), 31 = Y-Axis Full Band Peak Acceleration Frequency (Hz) (6-5300Hz), 32 = Z-Axis Full Band Peak Acceleration Frequency (Hz) (6-5300Hz), 33 = Magnitude (XYZ) High-Frequency RMS Acceleration* (G) (1000-53), 34 = X-Axis Full Band RMS Acceleration (G)(6-5300Hz), 35 = Y-Axis Full Band RMS Acceleration (G)(6-5300Hz), 36 = Z-Axis Full Band RMS Acceleration (G)(6-5300Hz), 37 = X-Axis RMS Velocity (mm/sec) (6-1000Hz), 39 = Y-Axis RMS Velocity (mm/sec) (6-1000Hz), 41 = Z-Axis RMS Velocity (mm/sec) (6-1000Hz), 43 = Temperature (°C)		
	17	Metric 06 - Warning Threshold	32		0	RW
	18	Metric 06 - Alarm Threshold	32		0	RW

Continued on page 41

Continued from page 40

Index	Subindex	Name	Length	Value Range	Default	Access Rights
				0 = Disable, 1 = X-Axis RMS Velocity (in/sec) (6-1000Hz), 2 = X-Axis High-Frequency RMS Acceleration (G)(1000-5300Hz), 3 = Y-Axis RMS Velocity (in/sec) (6-1000Hz), 4 = Y-Axis High-Frequency RMS Acceleration (G)(1000-5300Hz), 5 = Z-Axis RMS Velocity (in/sec) (6-1000Hz), 6 = Z-Axis High-Frequency RMS Acceleration (G)(1000-5300Hz), 7 = Temperature (°F), 8 = X-Axis Full Band Pk to Pk Acceleration (G)(6-5300Hz), 9 = Y-Axis Full Band Pk to Pk Acceleration (G)(6-5300Hz), 10 = Z-Axis Full Band Pk to Pk Acceleration (G)(6-5300Hz), 11 = X-Axis High-Frequency Pk Acceleration (G)(1000-5300Hz), 12 = Y-Axis High-Frequency Pk Acceleration (G)(1000-5300Hz), 13 = Z-Axis High-Frequency Pk Acceleration (G)(1000-5300Hz), 14 = X-Axis High-Frequency Crest Factor(1000-5300Hz), 15 = Y-Axis High-Frequency Crest Factor(1000-5300Hz), 16 = Z-Axis High-Frequency Crest Factor(1000-5300Hz), 17 = X-Axis High-Frequency Kurtosis(1000-5300Hz), 18 = Y-Axis High-Frequency Kurtosis(1000-5300Hz), 19 = Z-Axis High-Frequency Kurtosis(1000-5300Hz), 20 = X-Axis Full Band Crest Factor (6-5300Hz), 21 = Y-Axis Full Band Crest Factor (6-5300Hz), 22 = Z-Axis Full Band Crest Factor (6-5300Hz), 23 = X-Axis Full Band Kurtosis (6-5300Hz), 24 = Y-Axis Full Band Kurtosis (6-5300Hz), 25 = Z-Axis Full Band Kurtosis (6-5300Hz), 26 = X-Axis Peak Velocity Component Frequency (Hz) (6-1000Hz), 27 = Y-Axis Peak Velocity Component Frequency (Hz) (6-1000Hz), 28 = Z-Axis Peak Velocity Component Frequency (Hz) (6-1000Hz), 29 = Motor Run Flag,		
	19	Vibration Characteristics Selection 7	16		7	RW

Continued on page 42

Continued from page 41

Index	Subindex	Name	Length	Value Range	Default	Access Rights
				30 = X-Axis Full Band Peak Acceleration Frequency (Hz) (6-5300Hz), 31 = Y-Axis Full Band Peak Acceleration Frequency (Hz) (6-5300Hz), 32 = Z-Axis Full Band Peak Acceleration Frequency (Hz) (6-5300Hz), 33 = Magnitude (XYZ) High-Frequency RMS Acceleration* (G) (1000-53), 34 = X-Axis Full Band RMS Acceleration (G)(6-5300Hz), 35 = Y-Axis Full Band RMS Acceleration (G)(6-5300Hz), 36 = Z-Axis Full Band RMS Acceleration (G)(6-5300Hz), 37 = X-Axis RMS Velocity (mm/sec) (6-1000Hz), 39 = Y-Axis RMS Velocity (mm/sec) (6-1000Hz), 41 = Z-Axis RMS Velocity (mm/sec) (6-1000Hz), 43 = Temperature (°C)		
	20	Metric 07 - Warning Threshold	32		0	RW
	21	Metric 07 - Alarm Threshold	32		0	RW
	22	Vibration Characteristics Selection	16	0-65535	0	RW
88	1	Vib IQ Status	16	0 = IDLE, 1 = START, 2 = SAMPLES ACQUIRING, 3 = PROCESSING 4 = ACTIVE	0	RO
	2	Baseline Configuration	16	0-65535	0	RO
89		Vibe IQ Sampling	16	1 = Fmax 5300HZ, 2= Fmax 2650HZ, 3 = Fmax 1300HZ, 4 = Fmax 650HZ, 5 = Fmax 325HZ	1	RW
90	1	Start Baseline	16	0 = IDLE, 1 = TRIGGER BASELINE, 2 = BASELINE ABORD/RESET	0	RW
	2	Velocity Threshold Compare	16	0 = VELOCITY THRESHOLD OR WITH AXIS, 1 = VELOCITY THRESHOLD AND WITH AXIS	0	RW
	3	Accel Component for Threshold	16	0-65535	0	RW
	4	Accel Velocity or and Threshold Exceed for Baseline	16	0-65535	0	RW
	5	Number of Samples for baseline	16	0-65535	300	RW
	6	Sample Rate in seconds for baseline	16	0-65535	1	RW
	7	Number of Samples for Acute	16	0-255	5	RW
	8	Number of Samples for Chronic	16	0-255	100	RW
	9	Imperial Or Metric Selection	16	0 = Imperial, 1 = Metric	0	RW
91	1	X RMS Velocity Threshold for Baseline Value	16	0-65535	0	RW
	2	Y RMS Velocity Threshold for Baseline Value	16	0-65535	0	RW
	3	Z RMS Velocity Threshold for Baseline Value	16	0-65535	0	RW
	4	X RMS HP Acceleration Threshold for Baseline Value	16	0-65535	0	RW
	5	Y RMS HP Acceleration Threshold for Baseline Value	16	0-65535	0	RW
	6	Z RMS HP Acceleration Threshold for Baseline Value	16	0-65535	0	RW

Continued on page 43

Continued from page 42

Index	Subindex	Name	Length	Value Range	Default	Access Rights
92	1	X RMS Velocity Threshold for Baseline Value	16	0-65535	0	RW
	2	Y RMS Velocity Threshold for Baseline Value	16	0-65535	0	RW
	3	Z RMS Velocity Threshold for Baseline Value	16	0-65535	0	RW
	4	X RMS HP Acceleration Threshold for Baseline Value	16	0-65535	0	RW
	5	Y RMS HP Acceleration Threshold for Baseline Value	16	0-65535	0	RW
	6	Z RMS HP Acceleration Threshold for Baseline Value	16	0-65535	0	RW
93	1	X RMS Velocity Threshold for Baseline Value	16	0-65535	0	RW
	2	Y RMS Velocity Threshold for Baseline Value	16	0-65535	0	RW
	3	Z RMS Velocity Threshold for Baseline Value	16	0-65535	0	RW
	4	X RMS HP Acceleration Threshold for Baseline Value	16	0-65535	0	RW
	5	Y RMS HP Acceleration Threshold for Baseline Value	16	0-65535	0	RW
	6	Z RMS HP Acceleration Threshold for Baseline Value	16	0-65535	0	RW
94	1	X RMS Velocity Threshold for Baseline Value	16	0-65535	0	RW
	2	Y RMS Velocity Threshold for Baseline Value	16	0-65535	0	RW
	3	Z RMS Velocity Threshold for Baseline Value	16	0-65535	0	RW
	4	X RMS HP Acceleration Threshold for Baseline Value	16	0-65535	0	RW
	5	Y RMS HP Acceleration Threshold for Baseline Value	16	0-65535	0	RW
	6	Z RMS HP Acceleration Threshold for Baseline Value	16	0-65535	0	RW
95	1	Temp Warning Threshold Value	16	0-65535	15000	RW
	2	Temp Alarm Threshold Value	16	0-65535	18000	RW

Chapter Contents

QM30VT3 IO-Link Wiring 44
 Installing the QM30VT3 Sensor 44

Chapter 4 Installation Instructions

QM30VT3 IO-Link Wiring

QM30VT3 with IO-Link wiring

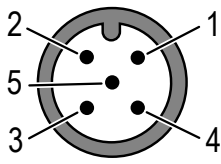
5-pin M12 Male Connector	Pin	Wire Color	Sensor Connection
	1	Brown (bn)	18-30 V DC
	2	White (wh)	Discrete OUT
	3	Blue (bu)	Ground
	4	Black (bk)	IO-Link
	5	Gray (gy)	No connection/not used

Installing the QM30VT3 Sensor

The vibration sensors have an X, Y, and Z axis indicated on the face of the sensor. Typically, in vibration analysis, the three axes are referred to as Axial (in line with the shaft of the asset), Horizontal Radial (parallel to the ground), Vertical Radial (perpendicular to the ground).

Not every application is identical so not every orientation will be the same. It is important to document the direction in which each axis is installed for labeling and diagnostic purposes.

An example install is to mount the sensor at the top center of a horizontally mounted motor with the X axis (parallel with the sensor cable) in line with the motor shaft or to mount the sensor with the Y axis (perpendicular to the sensor cable) perpendicular to the shaft in the horizontal radial axis and the Z axis (through plane of the sensor) going into or through the motor in the vertical radial axis.

For the best results, install the sensor as close to the motor bearing as possible. If this is not possible, install the sensor on a surface that is in rigid connection with the vibration characteristics of the motor.

Using a cover shroud or other flexible mounting location may result in a reduced accuracy or reduced ability to detect certain vibration characteristics. After determining the sensor direction and location, mount the sensor for the best possible vibration sensing accuracy.

Mounting Options	QM30 Housing Type	Description
BWA-QM30-FTAL (included with the aluminum housing model)	Aluminum	When available, directly mounting the bracket to the motor using an 1/4-28 × 1/2-inch screw provides a rigid surface with the highest sensor accuracy and frequency response. This mounting option offers flexibility for future sensor and bracket movement.
BWA-QM30-FTSS (included with the stainless steel housing model)	Stainless steel	Another mounting option is to use an epoxy to adhere the bracket to the motor. Banner recommends using an epoxy designed for accelerometer mounting, such as Loctite Depend 330 and 7388 activator. Epoxying a bracket to a motor provides a permanent installation of the bracket to which the sensor can be attached. This more rigid mounting solution ensures some of the best sensor accuracy and frequency response, but is not flexible for future adjustments. A third option is to use the included thermally conductive adhesive tape. This often provides a more than sufficient mounting type but does introduce some additional flex that reduces accuracy.

Continued on page 45

Continued from page 44

Mounting Options	QM30 Housing Type	Description
BWA-QM30-CEAL (curved bracket epoxied to the motor)	Aluminum	This lightweight aluminum bracket provides a close connection to the motor with ridges to sit on curved surfaces and ensure a tight fit. The bracket is epoxied to the motor and the sensor is screwed into the bracket.
BWA-QM30-FMSS (flat magnet bracket)	Aluminum and stainless steel	<p>Gives a solid, strong, and adjustable mount to a motor, but with a motor's curved surface it may not provide the best connection if the motor is too small for the magnet to get a full connection with the motor housing.</p> <p>Magnet mounts are susceptible to accident rotation or a change in the sensor location if an outside force bumps or moves the sensor. This can lead to a change in sensor information that differs from the time-trended data from the previous location.</p> <p>The bracket is stainless steel and the magnet insert is neodymium.</p>
BWA-QM30-CMAL (curved surface magnet bracket)	Aluminum and stainless steel	<p>Gives a solid, strong, and adjustable mount to a motor, intended for use when the flat magnetic bracket does not make a good connection with the motor's surface.</p> <p>Magnet mounts are susceptible to accidental rotation or change in the sensor location if an outside force bumps or moves the sensor. This can lead to a change in the sensor information that differs from the time-trended data from the previous location.</p> <p>The bracket is aluminum and the magnet insert is samarium-cobalt.</p>
BWA-QM30-FSALR (robust quick-release bracket)	Aluminum	This larger aluminum bracket mounts to the motor with a 1/4-28 × 1/2-inch screw to provide a rigid connection to the motor. On the right or left side, a setscrew is hand-tightened to secure the sensor to the bracket, allowing for rapid release and installation of a sensor compared to other mounting options.
BWA-QM30-FSSSR (robust quick-release bracket)	Stainless steel	This larger stainless steel bracket mounts to the motor with a 1/4-28 × 1/2-inch screw to provide a rigid connection to the motor. A set-screw is hand-tightened to secure the sensor to the bracket, allowing for rapid release and installation of a sensor compared to other mounting options.

Chapter Contents

Brackets 46
 Cordsets 47

Chapter 5 Accessories

Brackets

Bracket **BWA-QM30-FTAL** is included with the aluminium sensor models. Bracket **BWA-QM30-FTSS** is included with the stainless steel models. All other brackets are available for order, but are not included with the sensor.

BWA-QM30-FTSS

- Use when measuring high-frequency vibrations or when mounting the sensor to curved surfaces
- Includes stainless steel bracket, four mounting screws, and one 1/4-28 x 1/2 screw mount
- 30 mm x 30 mm
- CAD Files: [DXF](#), [PDF](#), [IGS](#), [STP](#)
- **Refer to the Bracket Assembly Quick Start Guide for installation instructions (p/n 213323)**

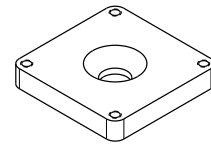

BWA-QM30-FTAL

- Use when measuring high-frequency vibrations or when mounting the sensor to curved surfaces
- Includes aluminum bracket, four mounting screws, one 1/4-28 x 1/2 screw mount, and one piece of 3M™ thermally conductive adhesive transfer tape
- 30 mm x 30 mm
- CAD Files: [DXF](#), [PDF](#), [IGS](#), [STP](#)
- **Refer to the Bracket Assembly Quick Start Guide for installation instructions (p/n 213323)**

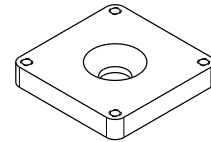

BWA-QM30-CEAL

- Epoxy-mount for curved surfaces
- Aluminum
- Set of five brackets
- CAD Files: [DXF](#), [PDF](#), [IGS](#), [STP](#)

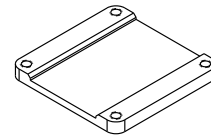

BWA-QM30-FSSSR Flat Surface Rapid Release Bracket (Stainless Steel)

- Circular bracket with center screw for mounting the bracket to the motor
- Side set-screw for quick-release mounting of the sensor to the bracket
- Stainless steel
- CAD Files: [DXF](#), [PDF](#), [IGS](#), [STP](#)

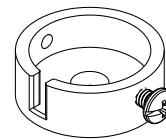

BWA-QM30-FMSS

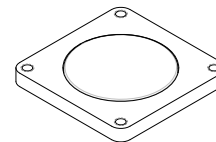

- Includes magnetic mounting bracket and four mounting screws (two sets of mounting screws for both the aluminum and stainless steel models)
- 30 mm x 30 mm
- CAD Files: [DXF](#), [PDF](#), [IGS](#), [STP](#)
- **Refer to the Bracket Assembly Quick Start Guide for installation instructions (p/n 213323)**

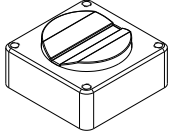
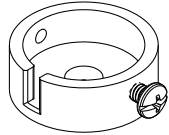
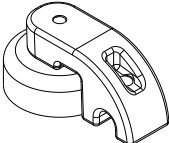

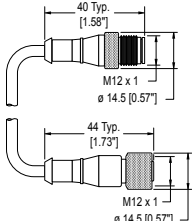
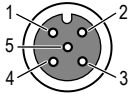

<p>BWA-QM30-CMAL</p> <ul style="list-style-type: none"> • Magnet mount for curved surfaces • 30 mm × 30 mm, 14.4 mm thick • Includes four M2.5 × 16 mm socket head cap screws • CAD Files: DXF, PDF, IGS, STP • Refer to the Bracket Assembly Quick Start Guide for installation instructions (p/n 213323) 	
<p>BWA-QM30-FSALR Flat Surface Rapid Release Bracket (Aluminum)</p> <ul style="list-style-type: none"> • Circular bracket with center screw for mounting the bracket to the motor • Side set-screw for quick-release mounting of the sensor to the bracket • Aluminum • CAD Files: DXF, PDF, IGS, STP 	
<p>BWA-QM30CAB-MAG</p> <ul style="list-style-type: none"> • QM30 Magnet Cable Placement Bracket BWA-BK-027 • Snap clip polypropylene bracket with magnetic backing for securing QM30 cables • Set of ten brackets in each container • CAD Files: DXF, PDF, IGS, STP 	

Cordsets

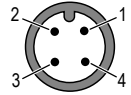
4-pin A-Code Double-Ended M12 Female to M12 Male Cordsets (datasheet p/n [236186](#))

Model	Length	Dimensions (mm)	Pinouts	
BC-M12F4-M12M4-22-1	1 m (3.28 ft)		<p>Female</p> 	<p>1 = Brown 2 = White 3 = Blue 4 = Black 5 = Unused</p> 
BC-M12F4-M12M4-22-2	2 m (6.56 ft)			
BC-M12F4-M12M4-22-3	3 m (9.84 ft)			
BC-M12F4-M12M4-22-4	4 m (13.12 ft)			
BC-M12F4-M12M4-22-5	5 m (16.4 ft)			
BC-M12F4-M12M4-22-10	10 m (30.81 ft)			
BC-M12F4-M12M4-22-15	15 m (49.2 ft)		<p>Male</p> 	

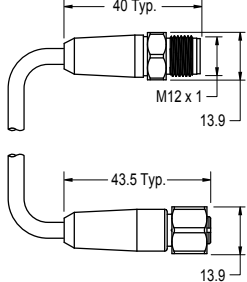
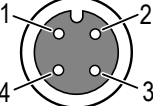
4-Pin Double-Ended M12 Female to M12 Male Washdown Stainless Steel Cordsets

Model	Length	Style	Dimensions	Pinout
MQDEC-WDSS-401SS	0.31 m (1 ft)	Male Straight/Female Straight		<p>Female</p> 
MQDEC-WDSS-403SS	0.91 m (2.99 ft)			
MQDEC-WDSS-406SS	1.83 m (6 ft)			
MQDEC-WDSS-412SS	3.66 m (12 ft)			<p>Male</p>  <p>1 = Brown 2 = White 3 = Blue 4 = Black</p>

Chapter Contents

Repairs	48
Contact Us	48
Banner Engineering Corp Limited Warranty	48

Chapter 6 Product Support and Maintenance

Repairs

Contact Banner Engineering for troubleshooting of this device. **Do not attempt any repairs to this Banner device; it contains no field-replaceable parts or components.** If the device, device part, or device component is determined to be defective by a Banner Applications Engineer, they will advise you of Banner's RMA (Return Merchandise Authorization) procedure.

IMPORTANT: If instructed to return the device, pack it with care. Damage that occurs in return shipping is not covered by warranty.

Contact Us

Banner Engineering Corp. | 9714 Tenth Avenue North | Plymouth, MN 55441, USA | Phone: + 1 888 373 6767

For worldwide locations and local representatives, visit www.bannerengineering.com.

Banner Engineering Corp Limited Warranty

Banner Engineering Corp. warrants its products to be free from defects in material and workmanship for one year following the date of shipment. Banner Engineering Corp. will repair or replace, free of charge, any product of its manufacture which, at the time it is returned to the factory, is found to have been defective during the warranty period. This warranty does not cover damage or liability for misuse, abuse, or the improper application or installation of the Banner product.

THIS LIMITED WARRANTY IS EXCLUSIVE AND IN LIEU OF ALL OTHER WARRANTIES WHETHER EXPRESS OR IMPLIED (INCLUDING, WITHOUT LIMITATION, ANY WARRANTY OF MERCHANTABILITY OR FITNESS FOR A PARTICULAR PURPOSE), AND WHETHER ARISING UNDER COURSE OF PERFORMANCE, COURSE OF DEALING OR TRADE USAGE.

This Warranty is exclusive and limited to repair or, at the discretion of Banner Engineering Corp., replacement. **IN NO EVENT SHALL BANNER ENGINEERING CORP. BE LIABLE TO BUYER OR ANY OTHER PERSON OR ENTITY FOR ANY EXTRA COSTS, EXPENSES, LOSSES, LOSS OF PROFITS, OR ANY INCIDENTAL, CONSEQUENTIAL OR SPECIAL DAMAGES RESULTING FROM ANY PRODUCT DEFECT OR FROM THE USE OR INABILITY TO USE THE PRODUCT, WHETHER ARISING IN CONTRACT OR WARRANTY, STATUTE, TORT, STRICT LIABILITY, NEGLIGENCE, OR OTHERWISE.**

Banner Engineering Corp. reserves the right to change, modify or improve the design of the product without assuming any obligations or liabilities relating to any product previously manufactured by Banner Engineering Corp. Any misuse, abuse, or improper application or installation of this product or use of the product for personal protection applications when the product is identified as not intended for such purposes will void the product warranty. Any modifications to this product without prior express approval by Banner Engineering Corp will void the product warranties. All specifications published in this document are subject to change; Banner reserves the right to modify product specifications or update documentation at any time. Specifications and product information in English supersede that which is provided in any other language. For the most recent version of any documentation, refer to: www.bannerengineering.com.

For patent information, see www.bannerengineering.com/patents.

